



CITY OF DRAPER

PROPERTY & PUBLIC RIGHTS OF WAY

ENCROACHMENT PERMIT APPLICATION & AGREEMENT

DRAPER CITY

1020 East Pioneer Road, Draper, UT 84020

Phone: (801) 576-6585

Email: engineering@draper.ut.us

<u>The Following items must be included with application</u>				*All lines must be completed and application must be signed*			
Diagram, Map or plans with location				Certificate of workers comp and liability insurance			
Traffic Control plan				Copy of State Contractor's License			
Work Area & Best Management practices (BMP or SWPPP) - See page 5							
<p>* All Digital files must be in PDF format, and labeled accurately*</p> <p>Applications will not be placed in review until all items listed above are received.</p>							
OWNER INFORMATION							
Application Date:			Anticipated Start Date:		Anticipated Duration Of Work (days):		
Name of Project/Development/Utility:					Utility/WO #:		
Name of Owner:			Owner Phone Number:		Owner Email:		
Owner Mailing Address:				City:	State:	Zip:	
24 Hr. Owner Contact:				24 Hr. Owner Phone Number:			
CONTRACTOR INFORMATION							
Contractor:				License # :			
Contractor Mailing Address:				City:	State:	Zip:	
Contractor Phone Number:				24 Hr. Contractor Contact:			
24 Hr. Phone Number:				24 Hr. Email:			
STREET CUT/ENCROACHMENT INFORMATION							
Address of Encroachment:							
Purpose of Encroachment:							
Type of work, check all that apply							
Overall area of work:		Length:	Width:	Materials to be used: Check all that apply			
Boring:		Length:	Width:	Concrete:	Asphalt:	Other:	
Cuts and/or Trenching				Boring with Pot holes? Y N		How Many:	
Street Cut:		Length:	Width:	To What Extent will this encroachment interfere with the normal flow of traffic on adjacent streets, sidewalks or Public Areas? (Attach Traffic control Plan, compliant with the Manual of Traffic control Devices/MUTCD)			
Sidewalk Cut:		Length:	Width:				
Curb and Gutter Cut :		Length:	Width:				
Park Strip Cut / Other:		Length:	Width:				
Manhole Access:		How Many:					

CONDITIONS OF APPROVAL

ENCROACHMENT PERMIT CASH BOND AMOUNTS One or All of the bond amounts may apply. (CASH SECURITY HELD FOR 1 YEAR)	\$2,000.00 per 100 longitudinal feet or fraction thereof \$2,000.00 per lateral excavation \$2,000.00 each encroachment
WINTER BOND AMOUNTS (FROM OCTOBER 15 TH THROUGH APRIL 15 TH)	Cash Security is Doubled
STORAGE OF MATERIAL IN THE RIGHT-OF-WAY	\$100.00
ROAD CLOSURES REQUIRE ADDITIONAL PERMIT & PRIOR AUTHORIZATION FROM CITY	

- **ALL** applications will be subject to a five (5) day waiting period after application has been submitted.
- Applicant is required to consult with the utility companies, within the project area, prior to the start of the encroachment. In granting this permit to encroach upon Draper City Property and/or its Public Rights of Way, the City of Draper makes no representation as to the location of utility facilities within the work area, or the effect of the permitted encroachment on the said utilities. In addition, no authorization is given or inferred by this permit to allow access onto private property. Owner’s written permission is required to be attached to the permit application, if a work plan includes access onto private property, including private lanes.
- In consideration for the granting of an encroachment permit by the City of Draper, the above noted applicant hereby promises (1) to perform the encroachment in a professional manner, in conformance with the ordinances of the City of Draper (www.draper.ut.us) and (2) to hold harmless the City of Draper, its officers, agents, employees or servants from all other costs, damages and liabilities that may accrue or be claimed to accrue by reason of any work performed under a permit issued, pursuant to this application.

• 24 HOUR ADVANCE NOTICE REQUIRED •

• CONTRACTOR MUST NOTIFY INSPECTOR WHEN WORK IS TO BE STARTED, WHEN WORK IS COMPLETED AND WHEN MATERIALS ARE TO BE INSTALLED

- **Max permit duration = 10 Days Extensions by written Requests**
- **ENGINEERING INSPECTOR MAY BE REACHED AT (801) 831-6226**

By submitting this form electronically, you agree your electronic signature is the legal equivalent of your manual signature on this form as if actually signed by you in writing. By submitting this form electronically, you consent to be legally bound by this form's terms and conditions.

SIGNATURE OF APPLICANT:	PRINT NAME:	DATE:
-------------------------	-------------	-------

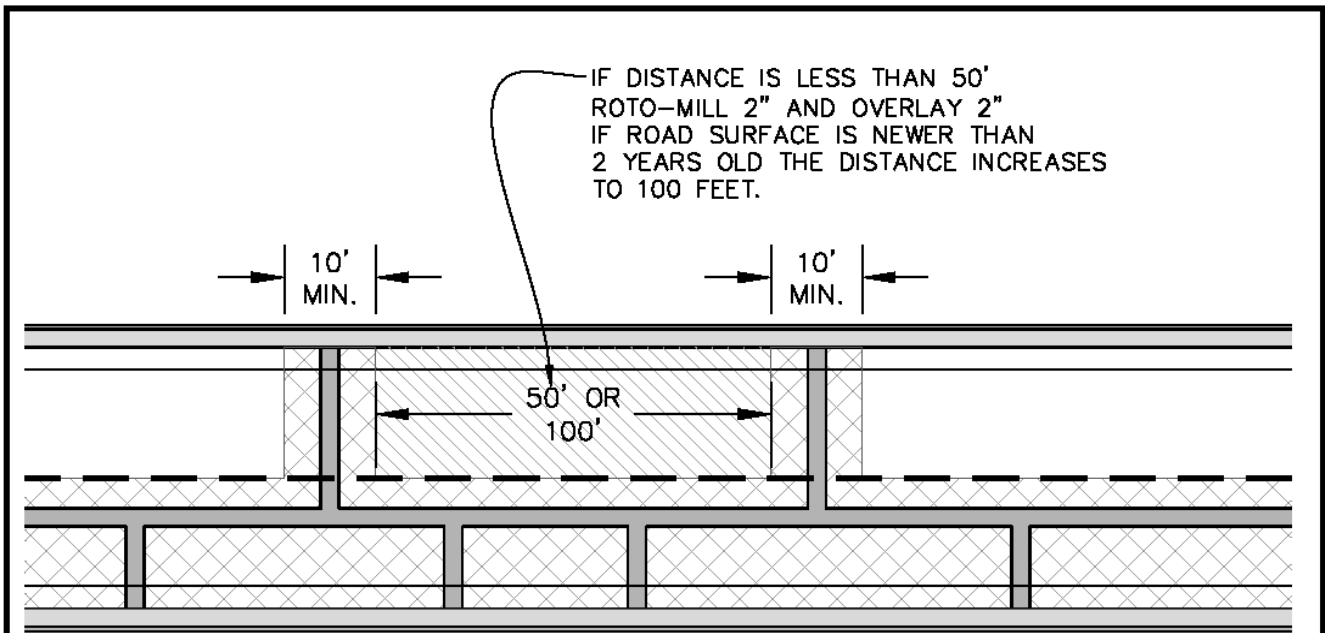



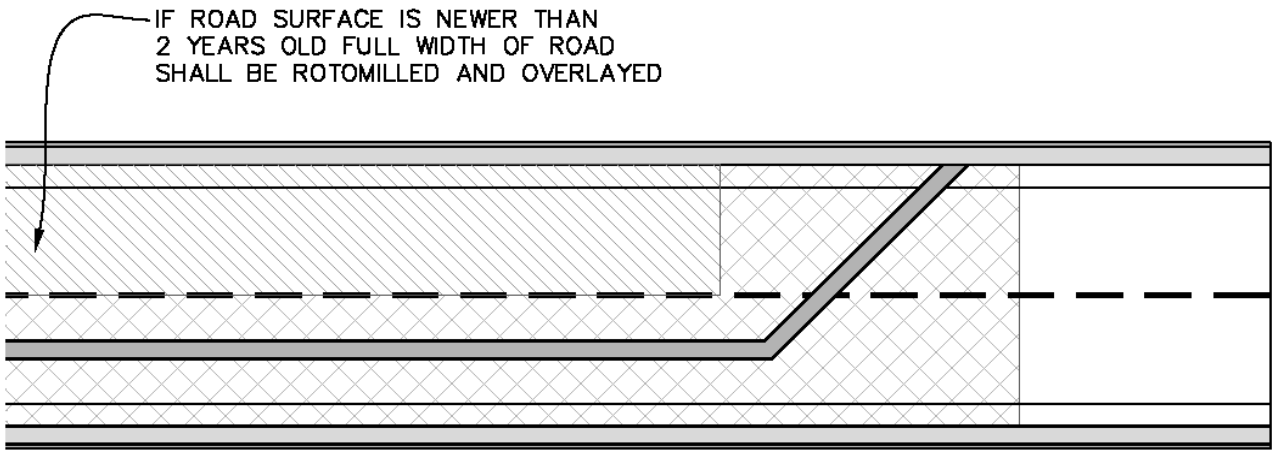

MULTIPLE EXCAVATIONS AND RESTORATION IN ASPHALT

NOTE:
 RESTORATION MUST BE A MINIMUM OF 10' CURB
 LENGTH BY THE WIDTH OF EACH LANE EXCAVATED



LOGITUDINAL EXCAVATION AND RESTORATION IN CONCRETE

-  AREA OF EXCAVATION
-  LIMITS OF RESTORATION OF EQUIVALENT ROAD SURFACE
(ROAD SURFACE OLDER THAN 2 YEARS)
-  LIMITS OF RESTORATION OF EQUIVALENT ROAD SURFACE
(ROAD SURFACE NEWER THAN 2 YEARS)

1	APPROVED		SEPT. 06	 DRAPER CITY	STREET REPAIR REQUIREMENTS	ST-19 1 of 2
NO.	AUTHORIZED BY	REVISIONS	DATE			

N:\Engineering\Draper City Standard Specifications & Details(2007-09)\UPDATED DWGS\ST-19.dwg, 10/18/2011 2:25:06 PM

N:\Engineering\Draper City Standard Specifications & Details(2007-08)\UPDATED DIMS\ST-19.dwg, 10/18/2011 2:24:27 PM

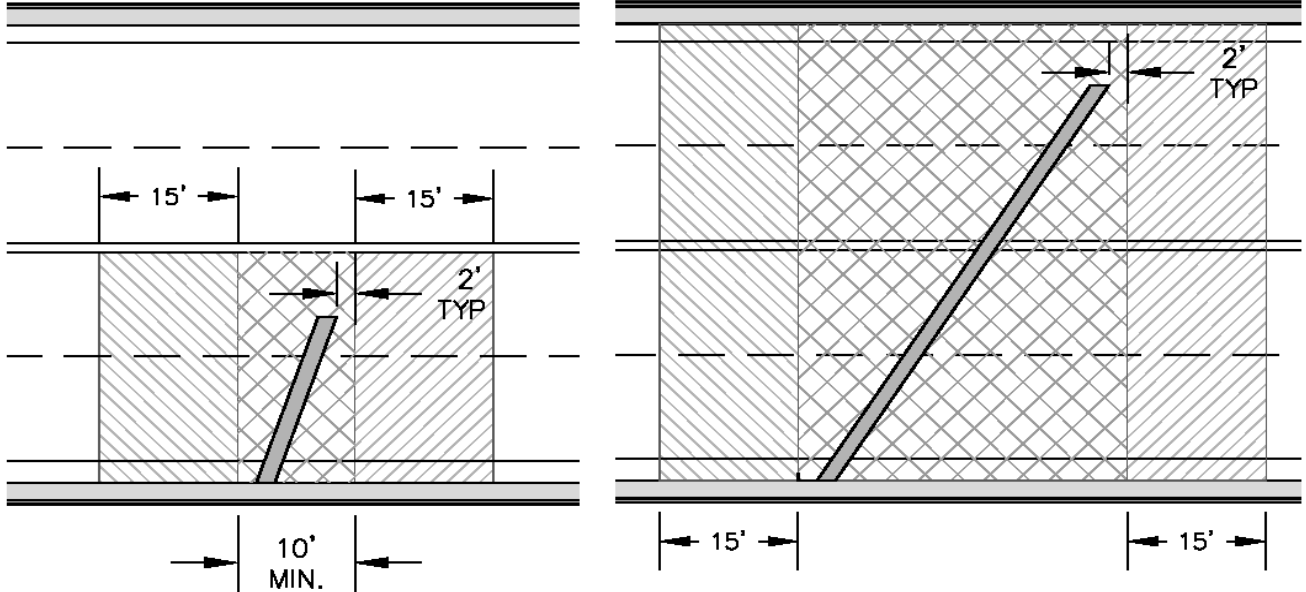

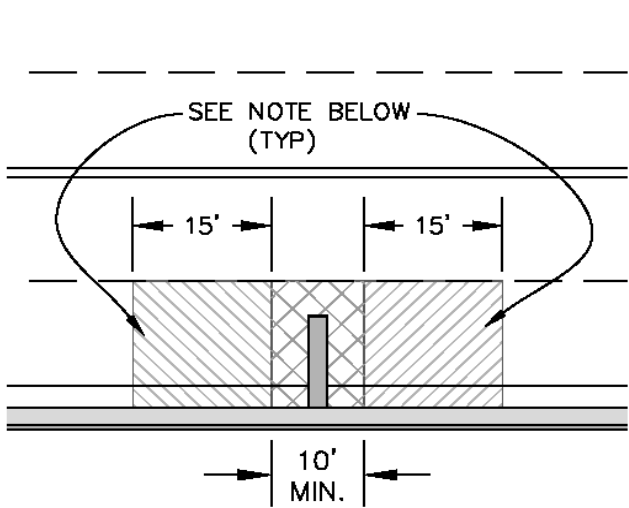

TRANSVERSE EXCAVATION AND RESTORATION

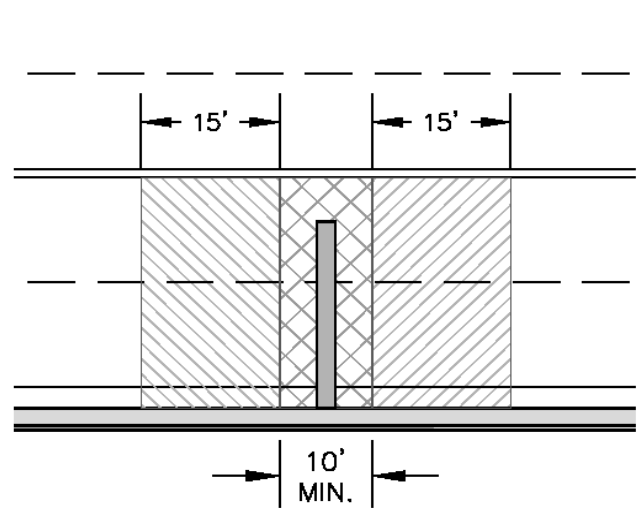

SINGLE LANE EXCAVATION AND RESTORATION



DOUBLE LANE EXCAVATION AND RESTORATION

-  AREA OF EXCAVATION
-  LIMITS OF RESTORATION
-  LIMITS OF OVERLAY AREA (2 YEARS OR NEWER)

NOTE:
 IF ROAD SURFACE IS 2 YRS. OR NEWER,
 CONTRACTOR SHALL ROTO-MILL EXISTING
 ROADWAY DOWN 2" & DO A 2" OVERLAY
 ON SAID AREA

1	APPROVED		SEPT. 06	 DRAPER CITY	<u>STREET REPAIR REQUIREMENTS</u>	ST-19 2 of 2
NO.	AUTHORIZED BY	REVISIONS	DATE			



DRAPER CITY ENCROACHMENT PERMIT-WORK AREA AND BMP MAP EXAMPLE

All BMPs in this example are for guidance only. Equivalent BMPs are acceptable per inspector's approval.

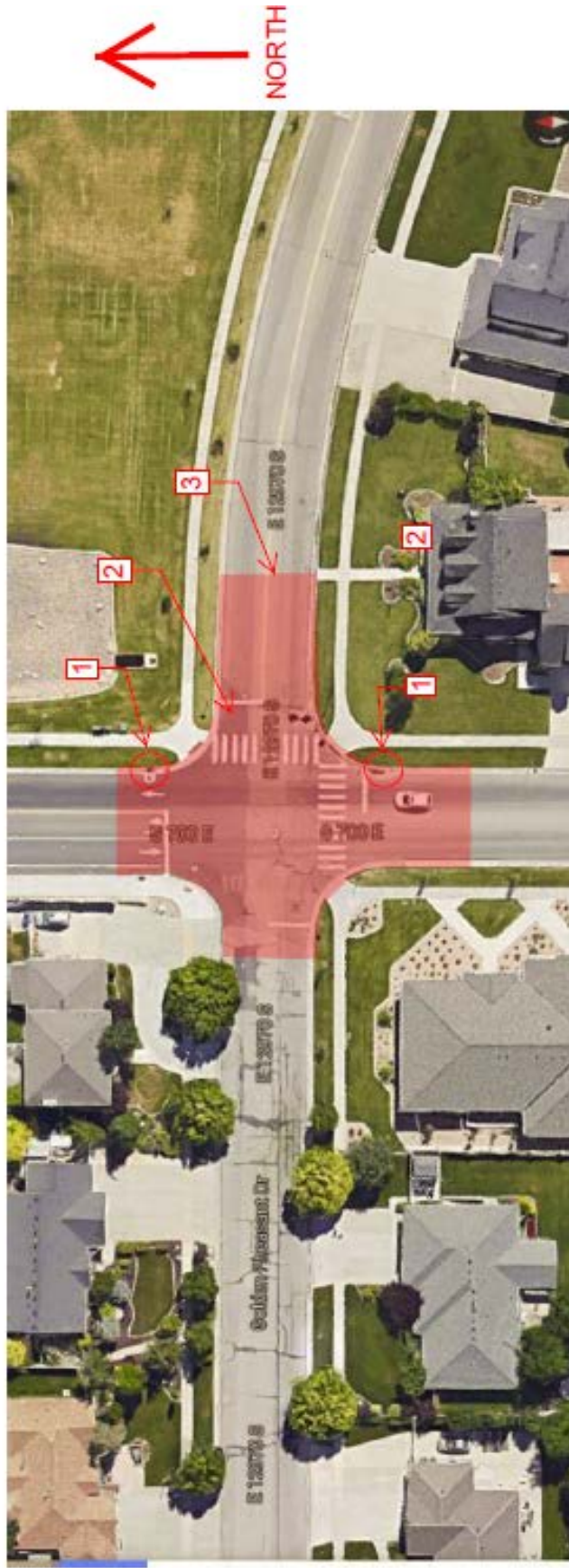

Best Management Practices (BMP)*

1. Install inlet protection down stream of project area to prevent sediment from being washed into storm drain system or other water body.
2. Sweep/pick up all construction debris off road, and dispose of daily and after project completion.
3. Outline of proposed work Area

*Applicant is responsible to identify and install any additional or needed BMPs in order to prevent pollution from entering the storm drain system or other water body.

N:\Engineering\2014 Archive\Draper City Standard Specifications & Details(2007-08)\UPDATED DWG\ST-21.dwg, 1/4/2016 11:39:53 AM

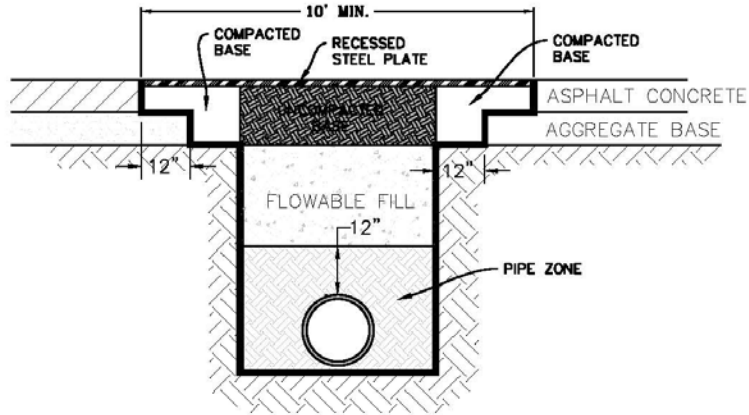

RECESSED STEEL PLATE DETAIL

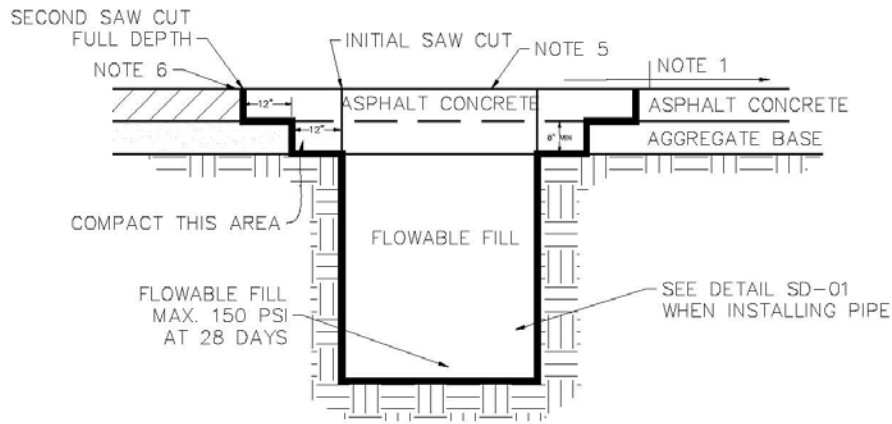

EXCAVATION ASPHALT PAVEMENT

EXCAVATION GENERAL NOTES

1. UNTREATED BASE COURSE: PROVIDE MATERIAL SPECIFIED IN SECTION 02230. PLACE AND COMPACT PER SECTION 02240 AND SECTION 02575. MAXIMUM LIFT THICKNESS IS 8-INCHES BEFORE COMPACTION.
2. SHORING: SHORE IN CONFORMANCE WITH SECTION 02214.
3. TACK COAT: FULL TACK COAT COVERAGE ON ALL VERTICAL SURFACES.
4. ASPHALT PAVEMENT: USE ASPHALT CONCRETE SPECIFIED IN SECTION 02513.
 - A. COMPACT EACH LIFT IN CONFORMANCE WITH SECTION 02503
 - B. PLANE OFF SURFACE DISTORTIONS THAT EXCEED 1/4 INCH DEVIATION IN 10 FEET.
 - C. COAT PLANED SURFACES WITH A CATIONIC OR ANIONIC EMULSION AS APPROVED BY CITY ENGINEER.
 - D. ASPHALT PAVEMENT THICKNESS DEPTH SHALL EQUAL EXISTING PLUS 1-INCH, 4" MINIMUM, 6" MAXIMUM
 - E. MATCH EXISTING ASPHALT GRADATION 1/2 OR 3/4.
5. JOINT REPAIR: IF A CRACK OCCURS AT THE "T" PATCH CONNECTION TO EXISTING PAVEMENT OR AT ANY STREET FIXTURE, SEAL THE CRACK PER SECTION 02511.
6. EQUIPMENT: ALL ASPHALT PAVEMENT SHALL BE INSTALLED WITH MECHANICAL PAVING EQUIPMENT UNLESS OTHERWISE APPROVED BY THE CITY ENGINEER.
7. COMPLY WITH ALL REQUIREMENTS OF SECTION 02575.
8. PLANT MIX SEAL COAT: FOR PLANT MIX SEAL COAT COMPLY WITH UDOT SPECIFICATION, SECTION 02786. MILL AND REPLACE EXISTING PLANT MIX SEAL COAT 10 FEET FROM EDGE OF SECOND CUT IN ALL DIRECTIONS.

1	APPROVED		SEPT. 06		TRENCH REPAIR DETAIL	ST-21
NO.	AUTHORIZED BY	REVISIONS	DATE	DRAPER CITY		